

±5 V, 250 mA Dual Output Power Supply

FEATURES

- 2.9 V to 5.0 V Input Voltage Range
- Fixed 5.0 V V_{POS} Output Voltage
 - 1% Output Voltage Accuracy
- Fixed 5.0 V V_{NEG} Output Voltage
 - 1% Output Voltage Accuracy
- Up to 250 mA Output Current from V_{POS} and V_{NEG}
- Excellent Line and Load Transient Response
- Operates in CCM Mode for Noise Free Output Voltage
- Boost Converter Able to Operate in "Down Mode" (V_{IN} close to or above V_{POS})
- High Converter Efficiency
- Short Circuit Protection
- Thermal Shutdown
- 3x3 mm 12 Pin QFN Package

DESCRIPTION

The TPS65133 is designed to drive LCD displays requiring a positive and negative supply rail. It may also be used as a general ±5 V supply for operational amplifiers or other devices requiring similar positive and negative supplies. The device integrates a boost converter and an inverting buck-boost converter suitable for battery operated products.

APPLICATIONS

- LCD Bias
- Active Matrix OLED
- Operational Amplifier Supply
- General ±5 V Power Supply

TYPICAL APPLICATION

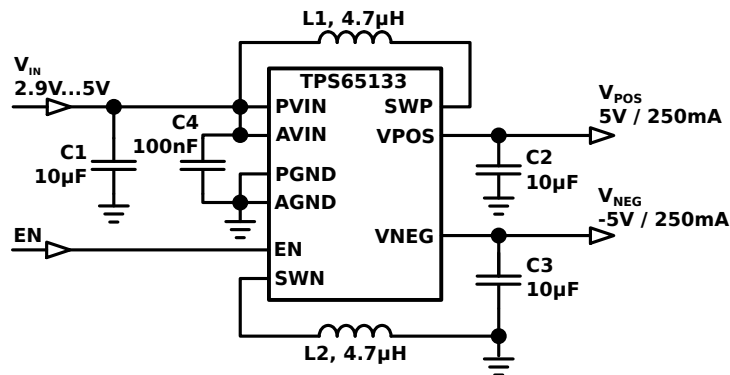

Please be aware that an important notice concerning availability, standard warranty, and use in critical applications of Texas Instruments semiconductor products and disclaimers thereto appears at the end of this data sheet.



These devices have limited built-in ESD protection. The leads should be shorted together or the device placed in conductive foam during storage or handling to prevent electrostatic damage to the MOS gates.

ORDERING INFORMATION⁽¹⁾ (2)

T _A	PACKAGE	ORDERING P/N	TOP-SIDE MARKING
-40°C to 85°C	12-Pin 3x3 QFN	TPS65133DPDR	SHY

- (1) For the most current package and ordering information, see the Package Option Addendum at the end of this document, or see the TI web site at www.ti.com.
 (2) Package drawings, thermal data, and symbolization are available at www.ti.com/packaging.

ABSOLUTE MAXIMUM RATINGS

over operating free-air temperature range (unless otherwise noted)⁽¹⁾

		VALUE		UNIT
		MIN	MAX	
Input voltage range ⁽²⁾	SWP, VPOS, PVIN, AVIN, EN	-0.3	6.0	V
	VNEG	-6.5	0.3	
	SWN	-6.5	5.5	
ESD rating	HBM		2	kV
	MM		200	V
	CDM		500	V
Operating junction temperature range	T _J	-40	150	°C
Operating ambient temperature range	T _A	-40	85	°C
Storage temperature range	T _{stg}	-65	150	°C

- (1) Stresses beyond those listed under *absolute maximum ratings* may cause permanent damage to the device. These are stress ratings only, and functional operation of the device at these or any other conditions beyond those indicated under *recommended operating conditions* is not implied. Exposure to absolute-maximum-rated conditions for extended periods may affect device reliability.
 (2) With respect to GND pin.

THERMAL INFORMATION

THERMAL METRIC ⁽¹⁾		QFN (12 PINS)	UNIT
θ _{JA}	Junction-to-ambient thermal resistance	51.5	°C/W
θ _{JB}	Junction-to-board thermal resistance	25.0	°C/W
Ψ _{JT}	Junction-to-top characterization parameter	0.5	°C/W
Ψ _{JB}	Junction-to-board characterization parameter	25.2	°C/W

- (1) For more information about traditional and new thermal metrics, see the IC Package Thermal Metrics application report, [SPRA953](http://www.ti.com/lit/zip/SPRA953).

RECOMMENDED OPERATING CONDITIONS⁽¹⁾

		MIN	NOM	MAX	UNIT
V _{IN}	Input voltage range	2.9	3.7	5	V
T _A	Operating ambient temperature	-40		85	°C
T _J	Operating junction temperature	-40		125	°C

- (1) Refer to application section for further information.

ELECTRICAL CHARACTERISTICS

$V_{IN} = 3.7V$, $EN = V_{IN}$, $V_{POS} = 5V$, $V_{NEG} = -5V$, $T_A = -40^{\circ}C$ to $85^{\circ}C$, typical values are at $T_A = 25^{\circ}C$ (unless otherwise noted)

PARAMETER		TEST CONDITIONS	MIN	TYP	MAX	UNIT
SUPPLY CURRENT AND THERMAL PROTECTION						
V_{IN}	Input voltage range		2.9		5	V
I_{SD}	Shutdown current into V_{IN}	$EN = GND$		0.1	15	μA
$UVLO$	Under-voltage lockout threshold	V_{IN} falling			2.1	V
		V_{IN} rising			2.5	
T_{SD}	Thermal shutdown temperature			135		$^{\circ}C$
LOGIC SIGNALS						
V_H	Logic high-level voltage		1.2			V
V_L	Logic low-level voltage				0.4	V
BOOST CONVERTER (V_{POS})						
V_{POS}	Positive output voltage		4.95	5	5.05	V
$R_{DS(ON)}$	SWP MOSFET on-resistance	$I_{SWP} = 200mA$	250			m Ω
	SWP MOSFET rectifier on-resistance		350			
f_{SWP}	SWP switching frequency	$I_{POS} = 200mA$	1.2	1.7	2.2	MHz
I_{SWP}	SWP switch current limit	Inductor valley current	0.8	1.1		A
$V_{P(SCP)}$	Short circuit threshold in operation	V_{POS} falling	4.1			V
$t_{P(SCP)}$	Short circuit detection time in operation		1	3	5	ms
$R_{P(DCG)}$	V_{POS} Discharge resistance	$EN = GND$, $I_{POS} = 1mA$	15	30	60	Ω
	Line regulation	$I_{POS} = 100 mA$.02			%/V
	Load regulation	$V_{IN} = 3.7 V$.24			%/A
BUCK-BOOST CONVERTER (V_{NEG})						
V_{NEG}	Negative output voltage default		-5.05	-5	-4.95	V
$R_{DS(ON)}$	SWN MOSFET on-resistance	$I_{SWN} = 200mA$	250			m Ω
	SWN MOSFET rectifier on-resistance		350			
f_{SWN}	SWN switching frequency	$I_{NEG} = 200mA$	1	1.7	2.4	MHz
I_{SWN}	SWN switch current limit	Inductor valley current	1.5	2.2		A
$V_{N(SCP)}$	Short circuit threshold in operation		-4.5			V
$t_{N(SCP)}$	Short circuit detection time in operation		1	3	5	ms
$R_{N(DCG)}$	V_{NEG} Discharge resistance	$EN = GND$, $I_{NEG} = 1mA$	100	150	200	Ω
	Start-up delay time after V_{POS} reaches target output to when V_{NEG} will begin startup		2			ms
	Line regulation	$I_{NEG} = 100 mA$.01			%/V
	Load regulation	$V_{IN} = 3.7 V$.16			%/A

DEVICE INFORMATION

**10 PIN TQFN PACKAGE
(TOP VIEW)**

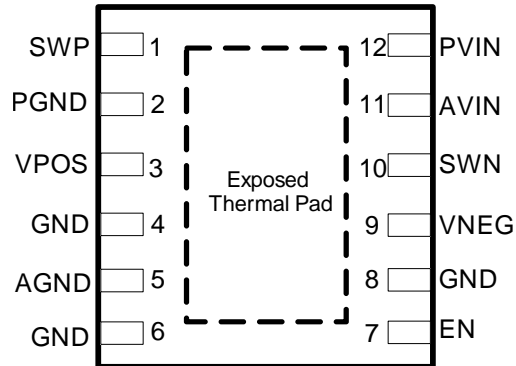
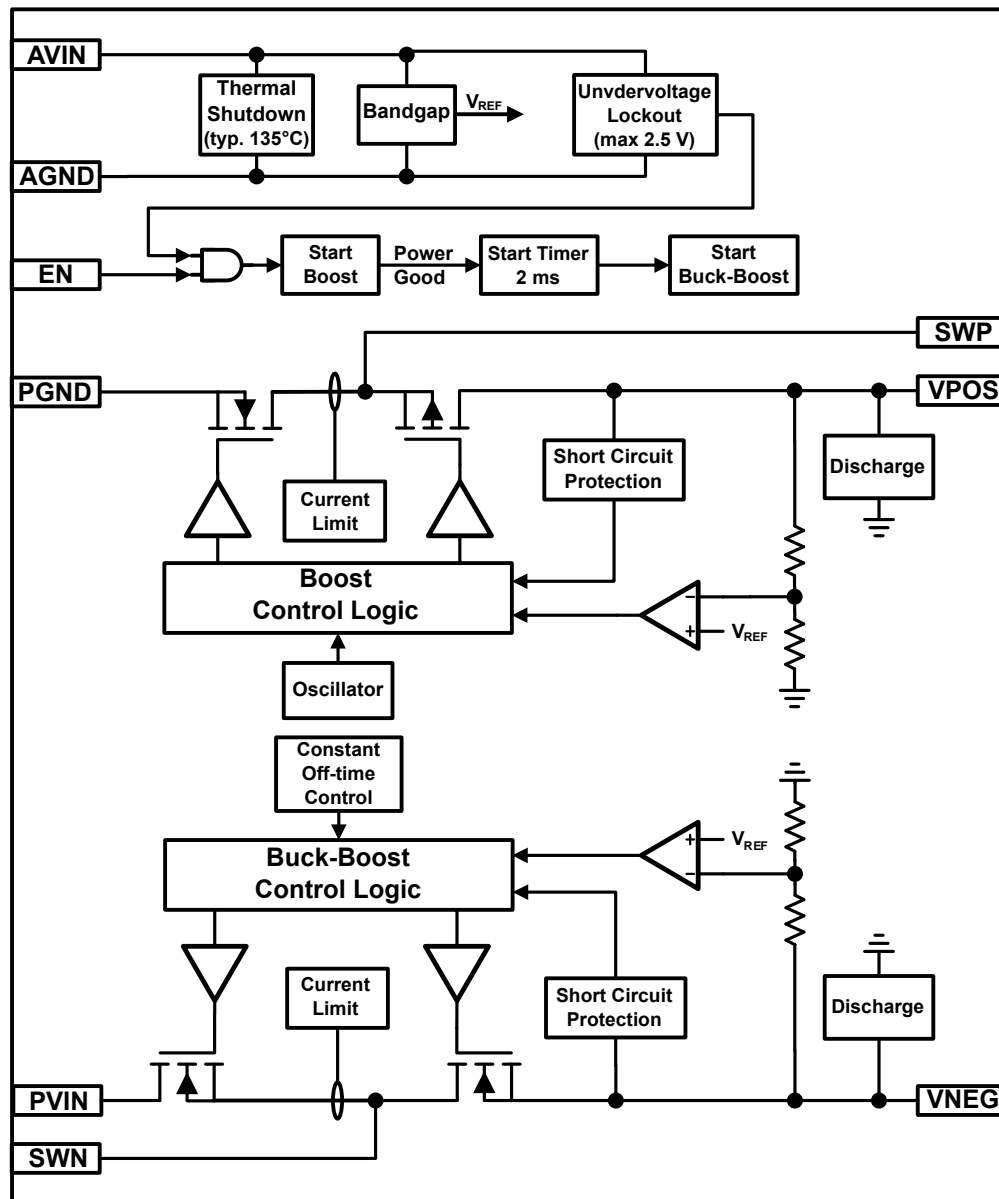

Table 1. Pin Functions

NO.	NAME	TYPE ⁽¹⁾	DESCRIPTION
1	SWP	I	Switch pin of the boost converter
2	PGND	G	Power ground of the boost converter
3	VPOS	O	Output of the boost converter (V_{POS}), place a capacitor close to this pin.
4	GND	G	Ground
5	AGND	G	Analog ground
6	GND	G	Ground
7	EN	I	Enable of boost and buck boost converter
8	GND	G	Ground
9	VNEG	O	Output of the negative buck boost converter (V_{NEG}), place a capacitor close to this pin
10	SWN	I	Switch pin of the negative buck boost converter
11	AVIN	I	Internal logic supply pin
12	PVIN	I	Supply pin for the negative buck boost converter. Place a capacitor close to this pin
—	Exposed thermal pad	G	Connect this pad to all GND pins

(1) G = Ground, I = Input, O = Output

FUNCTIONAL BLOCK DIAGRAM



TYPICAL CHARACTERISTICS

Table 2. Table of Graphs

		FIGURE
Efficiency vs. Output current	$V_{POS} = 5\text{ V}$, $V_{NEG} = -5\text{ V}$ $I_{OUT} = I_{POS} + I_{NEG}$, $I_{POS} = I_{NEG}$	Figure 1
Line Regulation	$V_{POS} = 5\text{ V}$, $V_{IN} = 2.9\text{ V to } 5.0\text{ V}$	Figure 2
	$V_{NEG} = -5\text{ V}$, $V_{IN} = 2.9\text{ V to } 5.0\text{ V}$	Figure 3
Startup	V_{POS} Boost and V_{NEG} Buck-Boost	Figure 4
Switch pin, inductor current and output waveform	V_{POS} Boost, $V_{POS} = 5\text{ V}$, $I_{OUT} = 100\text{ mA}$	Figure 5
	V_{POS} Boost, $V_{POS} = 5\text{ V}$, $I_{OUT} = 250\text{ mA}$	Figure 6
	V_{NEG} Buck-Boost, $V_{NEG} = -5\text{ V}$, $I_{OUT} = 100\text{ mA}$	Figure 7
	V_{NEG} Buck-Boost, $V_{NEG} = -5\text{ V}$, $I_{OUT} = 250\text{ mA}$	Figure 8
Load Transient	$V_{IN} = 3.7\text{ V}$, $I_{POS} = 50\text{ mA to } 200\text{ mA}$	Figure 9
	$V_{IN} = 3.7\text{ V}$, $I_{NEG} = 50\text{ mA to } 200\text{ mA}$	Figure 10

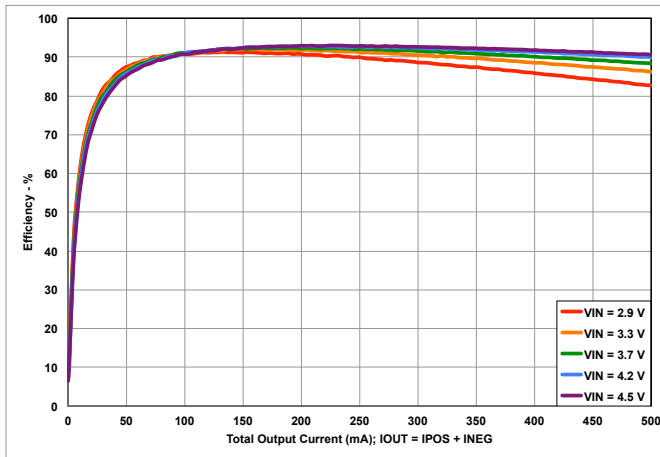

Figure 1. EFFICIENCY vs. OUTPUT CURRENT
 $V_{POS} = 5\text{ V}$, $V_{NEG} = -5\text{ V}$
 $I_{OUT} = I_{POS} + I_{NEG}$, $I_{POS} = I_{NEG}$

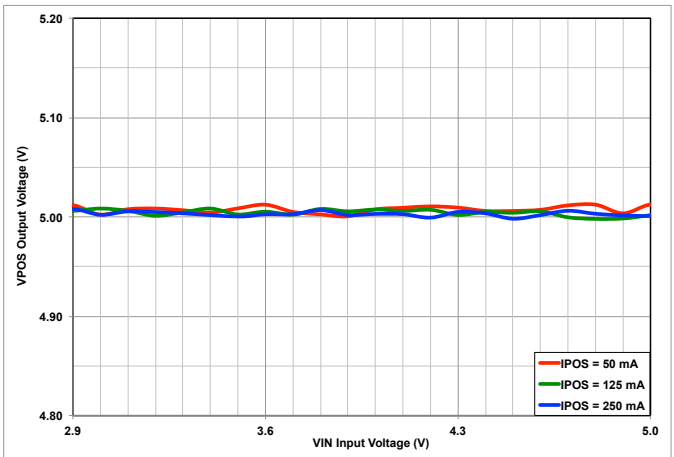

Figure 2. V_{POS} OUTPUT VOLTAGE vs. INPUT VOLTAGE
 $V_{POS} = 5\text{ V}$, $V_{IN} = 2.9\text{ V to } 5.0\text{ V}$

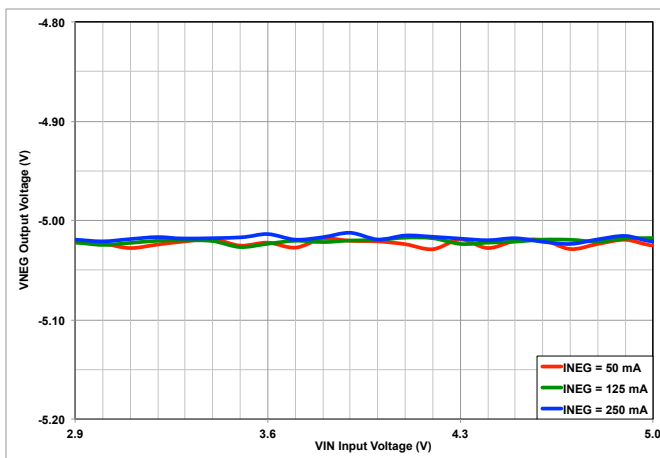
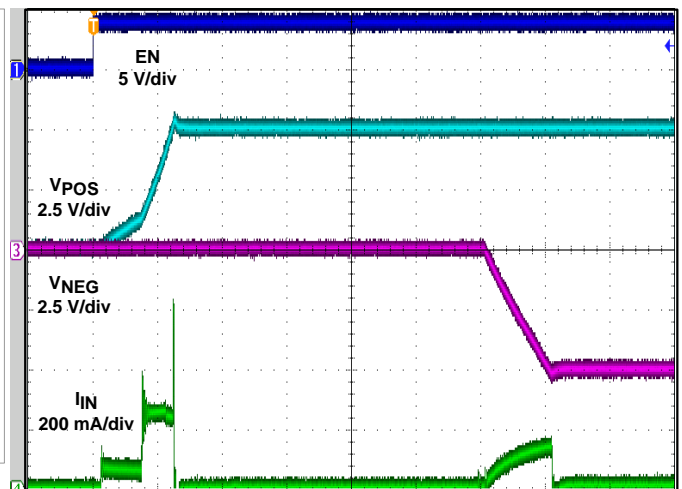

Figure 3. V_{NEG} OUTPUT VOLTAGE vs. INPUT VOLTAGE
 $V_{NEG} = -5\text{ V}$, $V_{IN} = 2.9\text{ V to } 5.0\text{ V}$



Time = 400 $\mu\text{s/div}$
Figure 4. START UP
 V_{POS} BOOST and V_{NEG} BUCK-BOOST

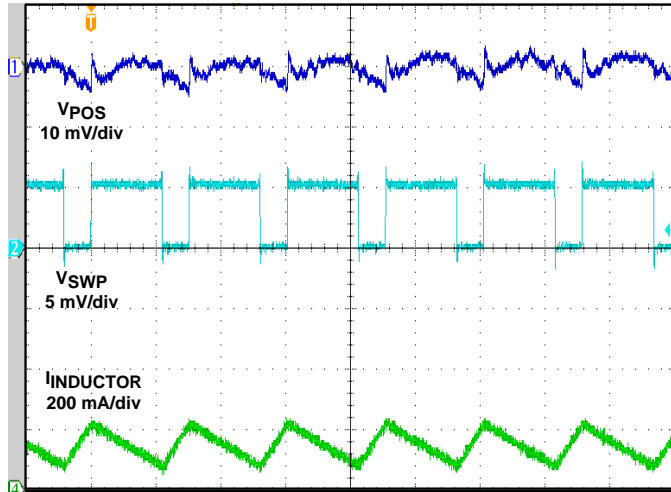

Figure 5. SWITCH PIN, INDUCTOR CURRENT and OUTPUT V_{POS} BOOST, V_{POS} = 5 V, I_{OUT} = 100 mA

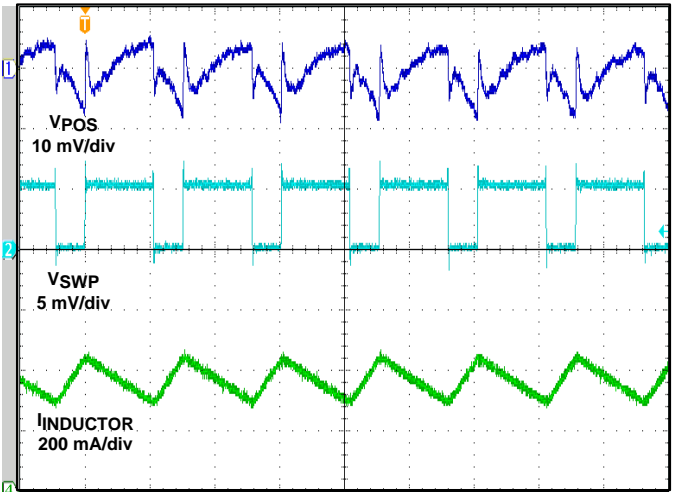

Figure 6. SWITCH PIN, INDUCTOR CURRENT and OUTPUT V_{POS} BOOST, V_{POS} = 5 V, I_{OUT} = 250 mA

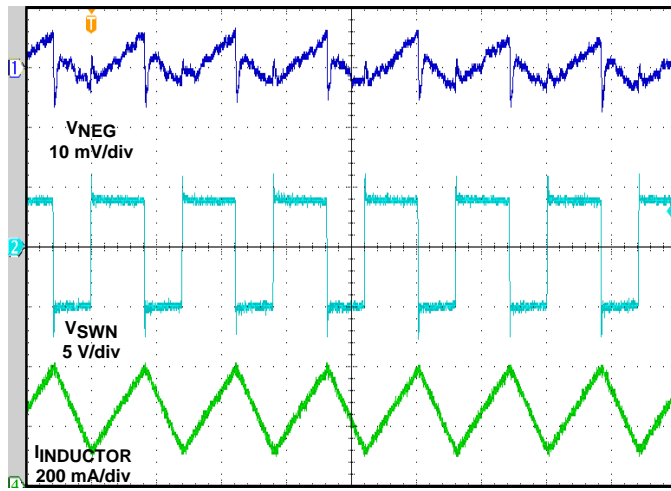

Figure 7. SWITCH PIN, INDUCTOR CURRENT and OUTPUT V_{NEG} BOOST, V_{NEG} = -5 V, I_{OUT} = 100 mA

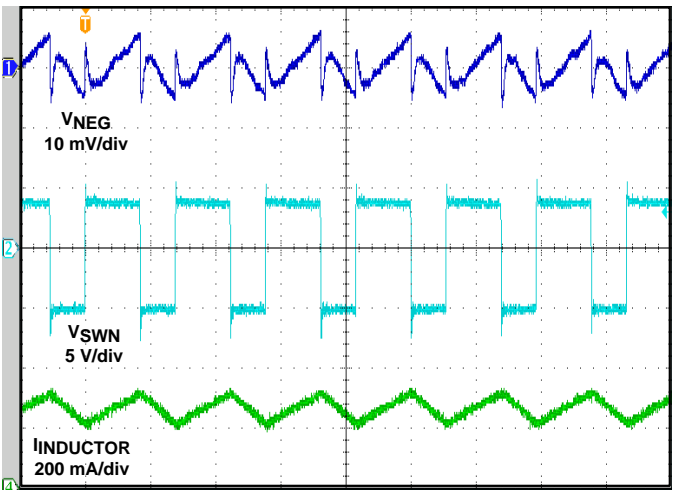

Figure 8. SWITCH PIN, INDUCTOR CURRENT and OUTPUT V_{NEG} BOOST, V_{NEG} = -5 V, I_{OUT} = 250 mA

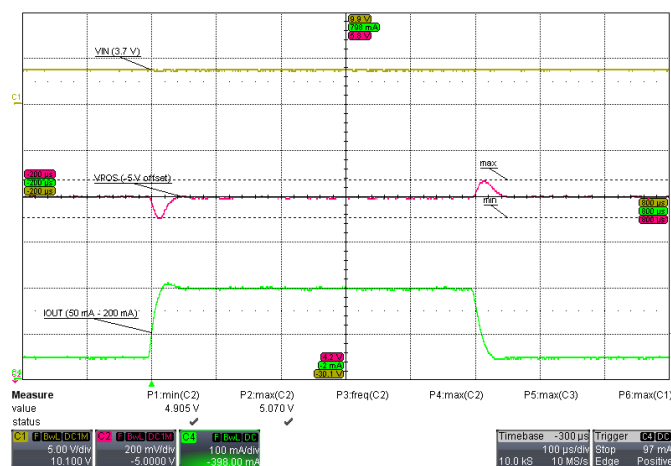

Figure 9. V_{POS} LOAD TRANSIENT VIN = 3.7 V, I_{POS} = 50 mA to 200 mA

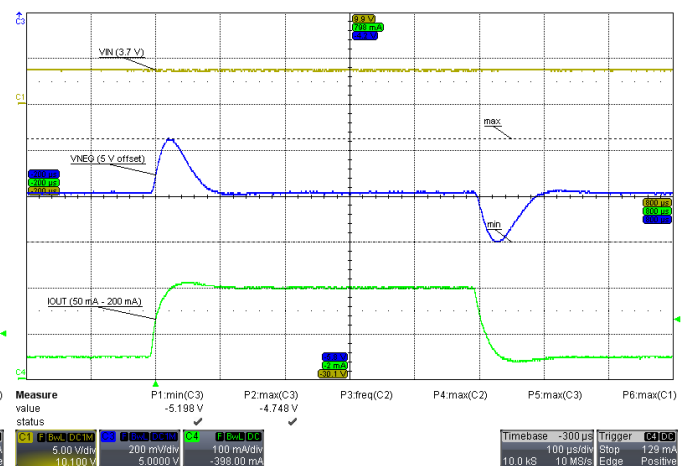

Figure 10. V_{NEG} LOAD TRANSIENT VIN = 3.7 V, I_{NEG} = 50 mA to 200 mA

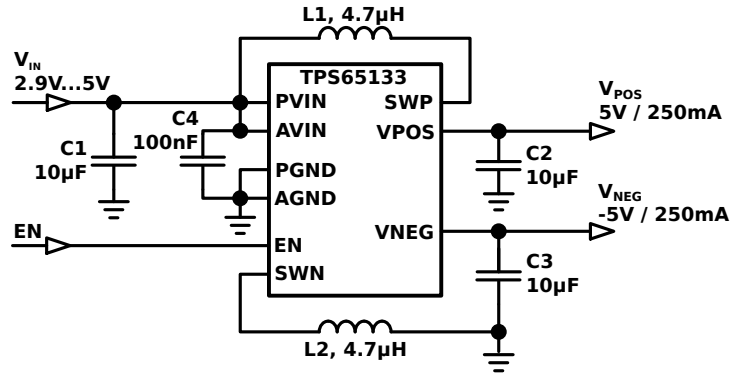

Figure 11. Application for Typical Characteristics

Table 3. Bill of Materials for Typical Characteristics

COMPONENT	VALUE	PART NUMBER	MANUFACTURER
C1, C2, C3	10µF	GRM219R61A106KE44	Murata
L1, L2	4.7µH	1239AS-H-4R7M (DFE 252012C)	TOKO

DETAILED DESCRIPTION

The TPS65133 integrates a boost converter and an inverting buck-boost converter. The positive output is fixed at 5 V and negative output is fixed at -5 V.

ENABLE (EN PIN)

The EN pin enables the boost and buck-boost converters. When EN is pulled high the device is enabled and both rails will startup according to the start-up sequence. When EN is pulled low the device is disabled and both outputs are discharged to ground.

START-UP AND SHUT-DOWN SEQUENCE

The device is enabled by EN pin going high, the boost converter (V_{POS}) will first start. Typically 2 ms after V_{POS} is in regulation, the buck-boost converter (V_{NEG}) starts. To reduce the inrush current, the switch current limit during start-up is reduced (soft-start). The start-up times depend on the output capacitances and the load currents.

During shut-down (EN = low) the outputs are actively discharged to GND, as long as $V_{IN} > 1.5$ V (typ). The discharge time depends on the output capacitance and the load current. The V_{POS} discharge circuit is stronger than the V_{NEG} discharge circuit, that means for the same output capacitance and load V_{POS} is discharged faster. The start-up and shut-down sequence for the typical application with 10 μ F output capacitance is shown in Figure 12.

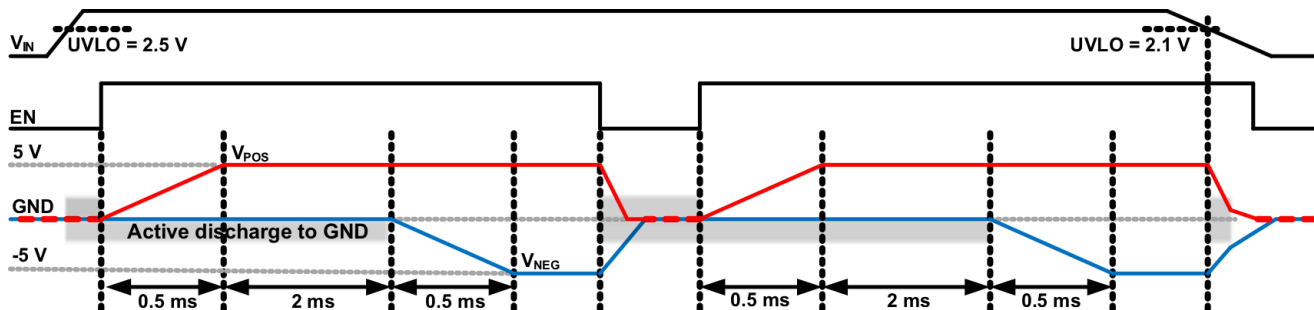

Figure 12. Start-up Sequence

INPUT VOLTAGE OPERATING RANGE

The TPS65133 is designed to work optimally over an input voltage range of 2.9V to 5V. However, as the input voltage drops below 2.9V and approaches the UVLO falling threshold (typically 2.1V), the device will continue to operate. The device is also able to function as the input voltage approaches the target output voltage of the switching converters; that is to say, as V_{IN} approaches and reaches 5V, the V_{POS} and V_{NEG} rails will continue to output +5V and -5V. The device is able to operate in a 'down' mode similar to an LDO in this condition as V_{IN} approaches and reaches 5V.

OUTPUT DISCHARGE

The device actively discharges V_{POS} and V_{NEG} to GND when the device is disabled (see Figure 12 shaded area).

SHORT CIRCUIT PROTECTION

The device is protected against short circuits of V_{POS} and V_{NEG} to GND.

Short Before Power-up:

When a short-circuit is present before power-up, the output current is limited until the short is removed.

Short During Operation:

A short-circuit is detected if V_{POS} falls below 4.1 V for longer than 3 ms or V_{NEG} is pulled above -4.5V longer than 3 ms. In either case, the device goes into shutdown and this state is latched. Input and outputs are disconnected. To resume normal operation, V_{IN} must cycle below UVLO or EN has to toggle from low to high.

THERMAL SHUTDOWN

A thermal shutdown is implemented to prevent damage because of excessive heat and power dissipation. Once a temperature of typically 135°C is exceeded the device goes into shutdown. To resume normal operation, V_{IN} must cycle below UVLO or EN has to toggle from low to high.

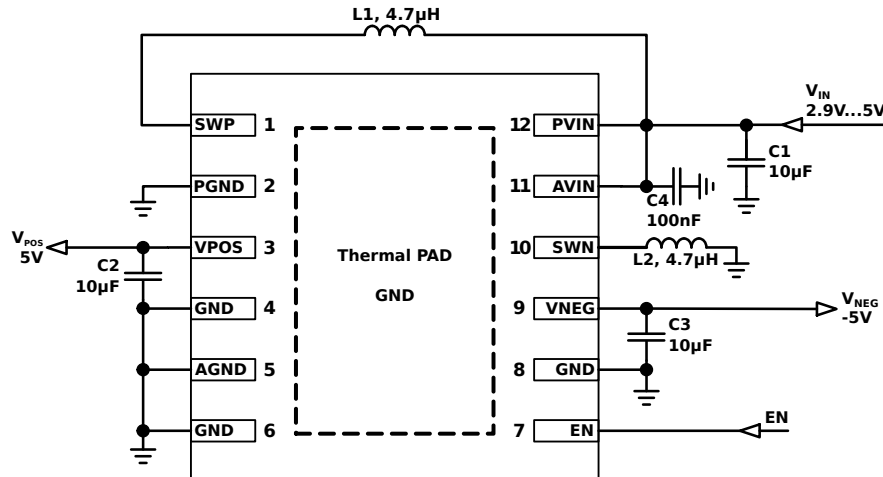

Figure 13. Typical Application Circuit

PCB LAYOUT

1. Place the input capacitor on PVIN and the output capacitor on VNEG as close as possible to device. Use short and wide traces to connect the input capacitor on PVIN and the output capacitor on VNEG.
2. Place the output capacitor on VPOS as close as possible to the device. Use short and wide traces to connect the output capacitor on VPOS.
3. Connect the ground of AVIN capacitor with AGND.
4. Connect input ground and output ground on the same board layer, not through via hole.
5. Connect AGND, PGND and GND with exposed thermal pad.

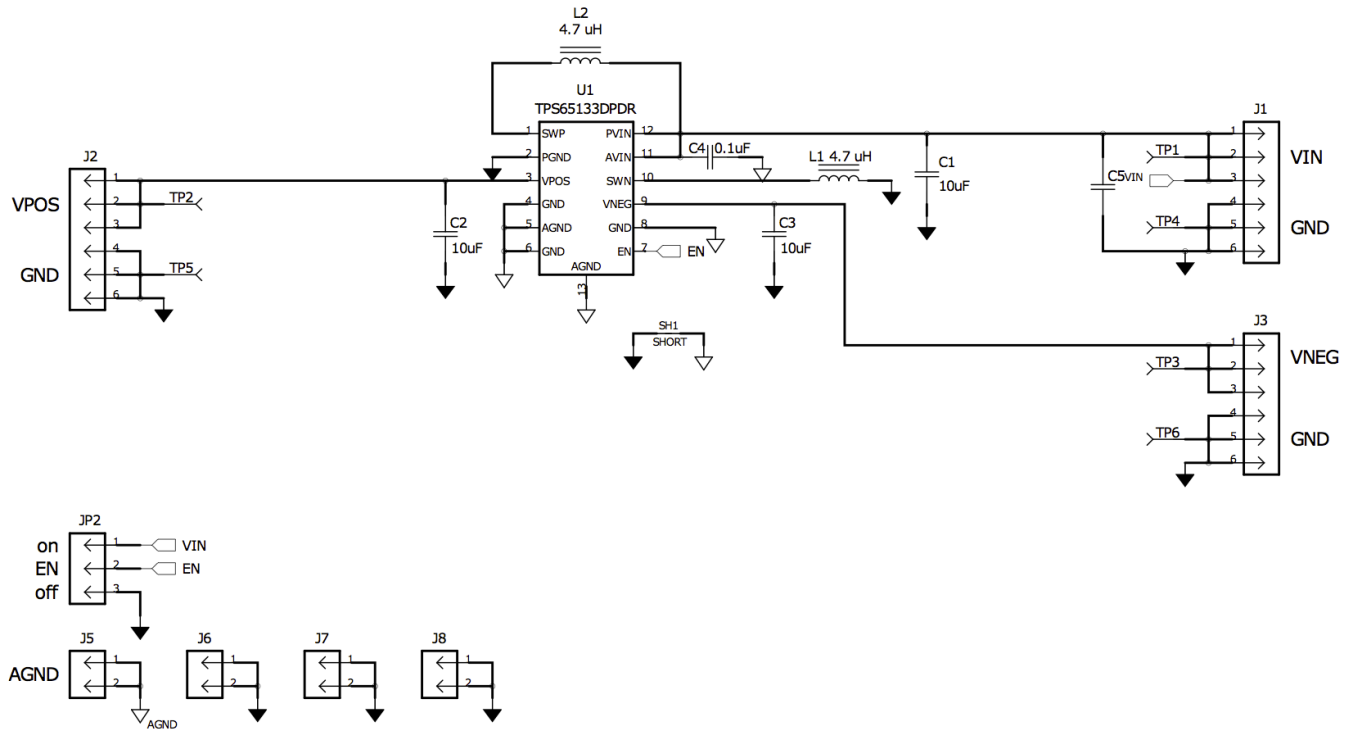

Figure 14. TPS65133 EVM Schematic

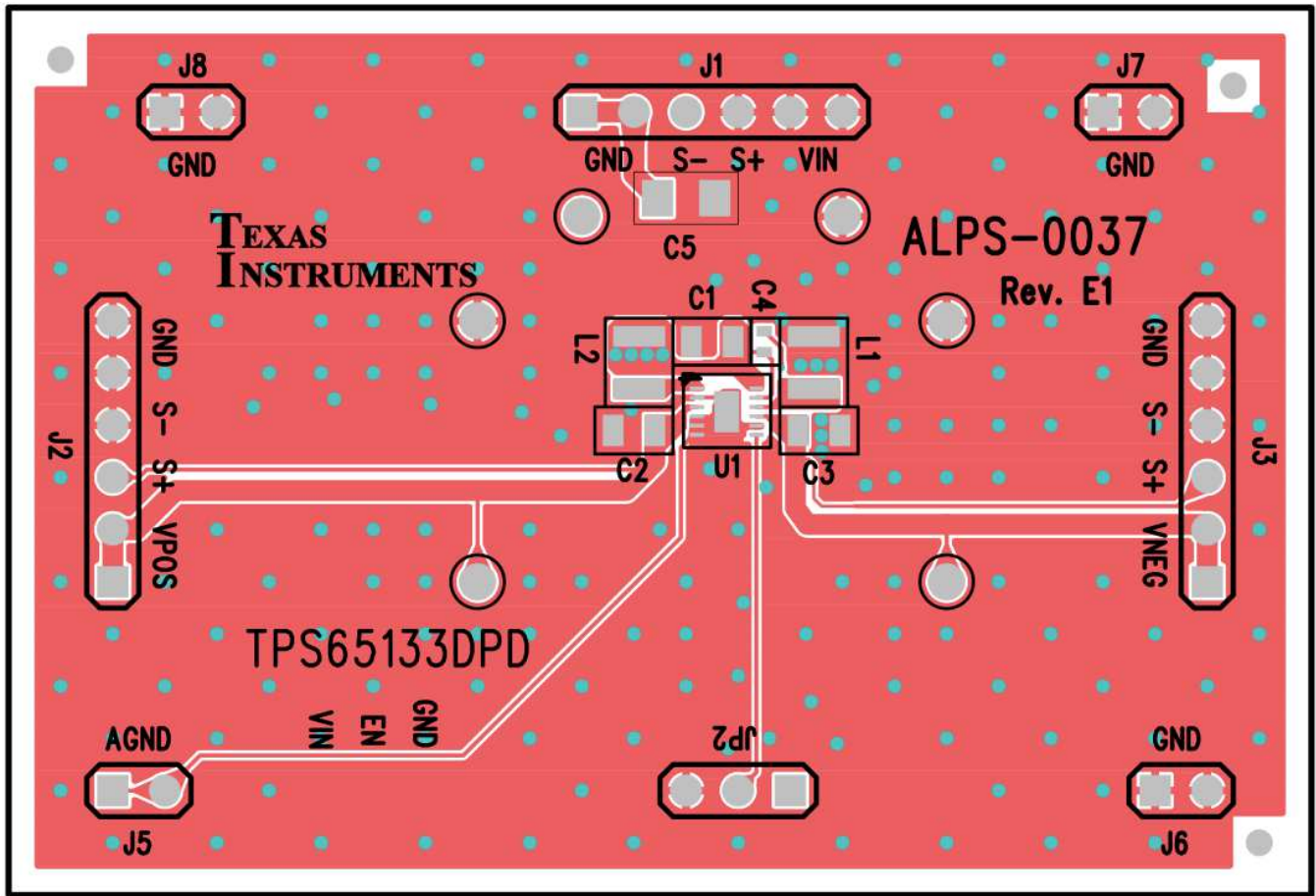

Figure 15. TPS65133 EVM Layout, Top Layer

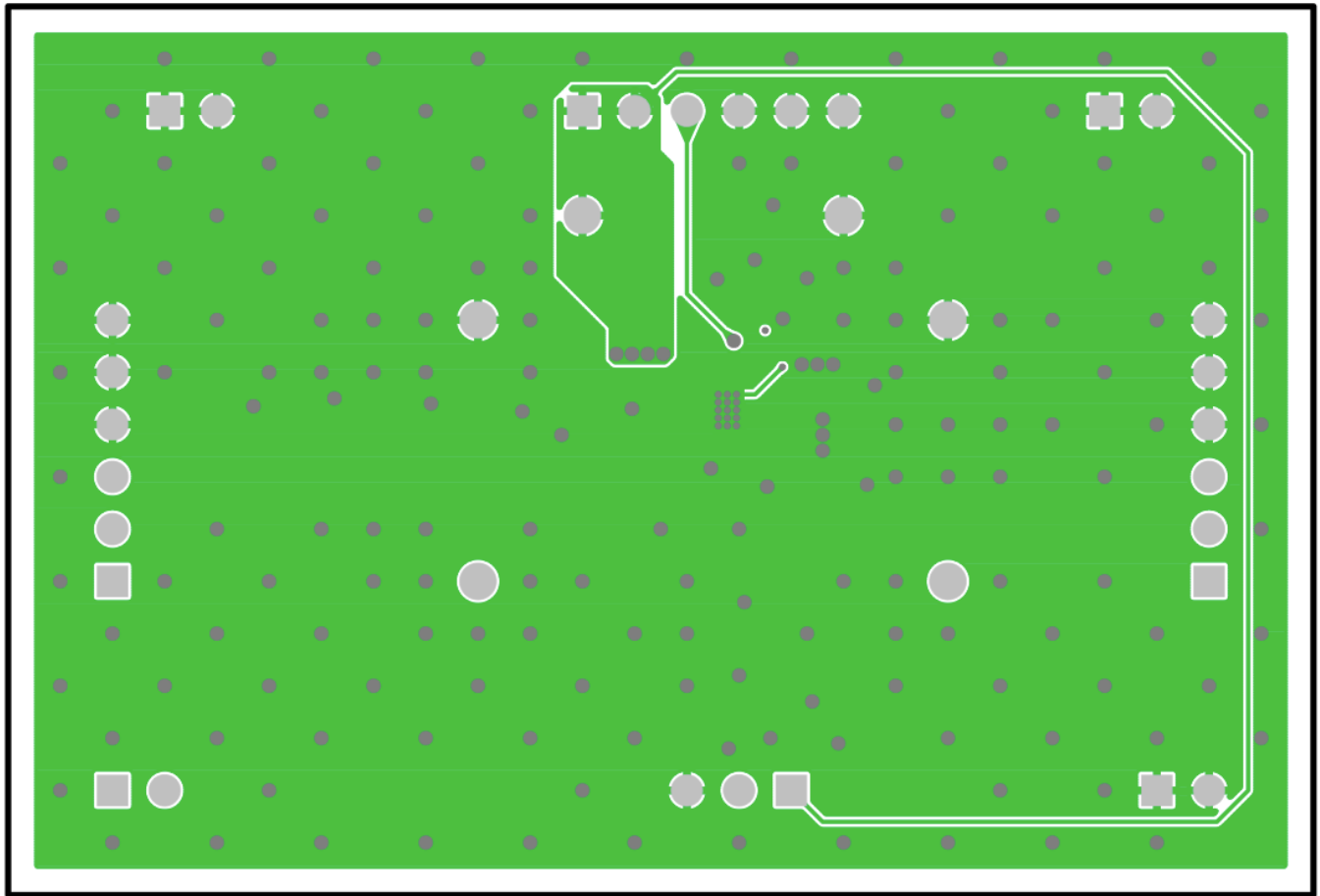

Figure 16. TPS65133 EVM Layout, Bottom Layer

PACKAGING INFORMATION

Orderable Device	Status (1)	Package Type	Package Drawing	Pins	Package Qty	Eco Plan (2)	Lead/Ball Finish	MSL Peak Temp (3)	Op Temp (°C)	Device Marking (4/5)	Samples
TPS65133DPDR	PREVIEW	WSON	DPD	12	3000	Green (RoHS & no Sb/Br)	CU NIPDAU	Level-2-260C-1 YEAR	-40 to 85	SHY	

(1) The marketing status values are defined as follows:

ACTIVE: Product device recommended for new designs.

LIFEBUY: TI has announced that the device will be discontinued, and a lifetime-buy period is in effect.

NRND: Not recommended for new designs. Device is in production to support existing customers, but TI does not recommend using this part in a new design.

PREVIEW: Device has been announced but is not in production. Samples may or may not be available.

OBSOLETE: TI has discontinued the production of the device.

(2) Eco Plan - The planned eco-friendly classification: Pb-Free (RoHS), Pb-Free (RoHS Exempt), or Green (RoHS & no Sb/Br) - please check <http://www.ti.com/productcontent> for the latest availability information and additional product content details.

TBD: The Pb-Free/Green conversion plan has not been defined.

Pb-Free (RoHS): TI's terms "Lead-Free" or "Pb-Free" mean semiconductor products that are compatible with the current RoHS requirements for all 6 substances, including the requirement that lead not exceed 0.1% by weight in homogeneous materials. Where designed to be soldered at high temperatures, TI Pb-Free products are suitable for use in specified lead-free processes.

Pb-Free (RoHS Exempt): This component has a RoHS exemption for either 1) lead-based flip-chip solder bumps used between the die and package, or 2) lead-based die adhesive used between the die and leadframe. The component is otherwise considered Pb-Free (RoHS compatible) as defined above.

Green (RoHS & no Sb/Br): TI defines "Green" to mean Pb-Free (RoHS compatible), and free of Bromine (Br) and Antimony (Sb) based flame retardants (Br or Sb do not exceed 0.1% by weight in homogeneous material)

(3) MSL, Peak Temp. -- The Moisture Sensitivity Level rating according to the JEDEC industry standard classifications, and peak solder temperature.

(4) There may be additional marking, which relates to the logo, the lot trace code information, or the environmental category on the device.

(5) Multiple Device Markings will be inside parentheses. Only one Device Marking contained in parentheses and separated by a "~" will appear on a device. If a line is indented then it is a continuation of the previous line and the two combined represent the entire Device Marking for that device.

Important Information and Disclaimer: The information provided on this page represents TI's knowledge and belief as of the date that it is provided. TI bases its knowledge and belief on information provided by third parties, and makes no representation or warranty as to the accuracy of such information. Efforts are underway to better integrate information from third parties. TI has taken and continues to take reasonable steps to provide representative and accurate information but may not have conducted destructive testing or chemical analysis on incoming materials and chemicals. TI and TI suppliers consider certain information to be proprietary, and thus CAS numbers and other limited information may not be available for release.

In no event shall TI's liability arising out of such information exceed the total purchase price of the TI part(s) at issue in this document sold by TI to Customer on an annual basis.

DPD (S-PWSON-N12)

PLASTIC SMALL OUTLINE NO-LEAD

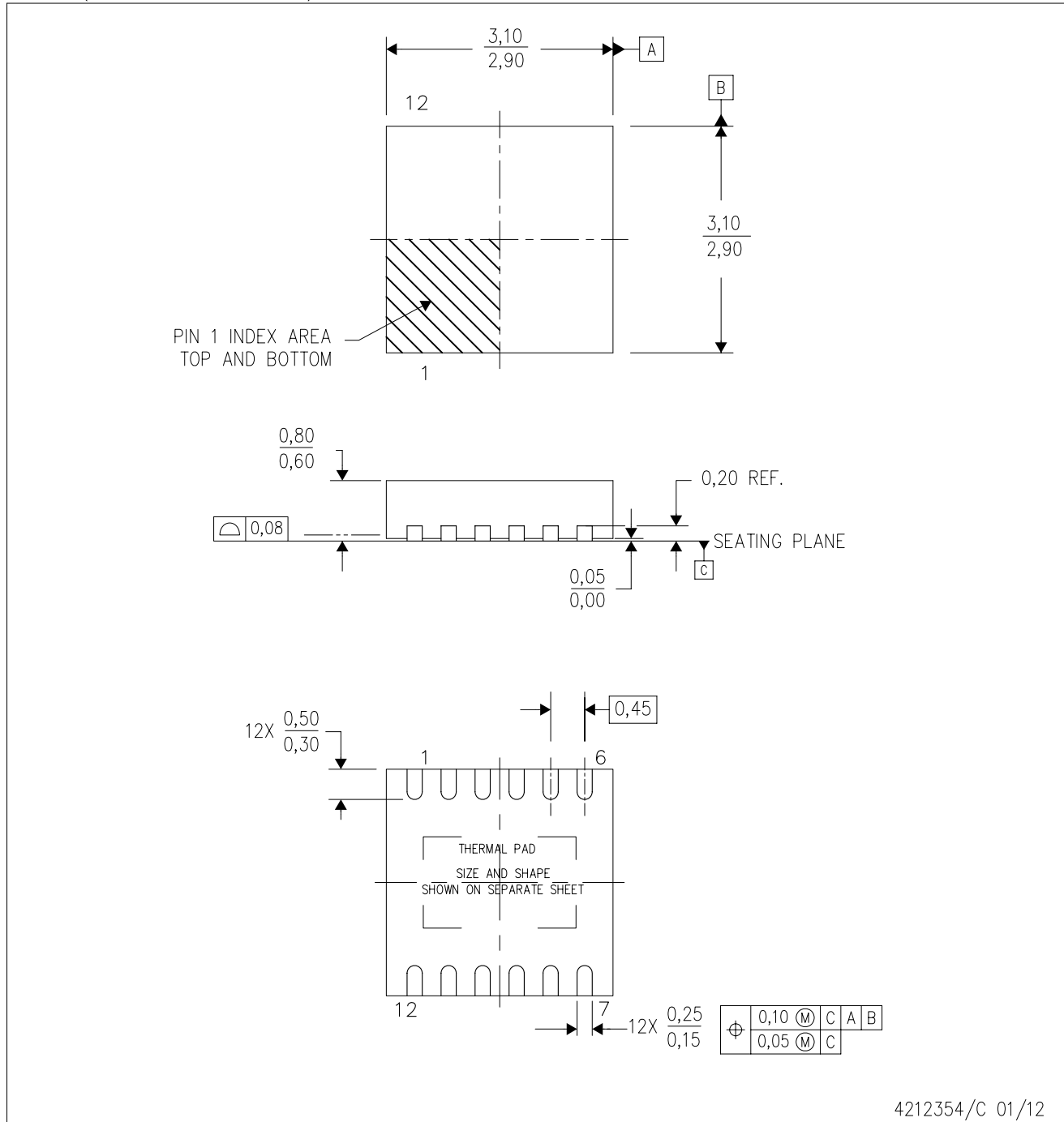

- NOTES:
- All linear dimensions are in millimeters. Dimensioning and tolerancing per ASME Y14.5M-1994.
 - This drawing is subject to change without notice.
 - Small Outline No-Lead (SON) package configuration.
 - The package thermal pad must be soldered to the board for thermal and mechanical performance, if present.
 - See the additional figure in the Product Data Sheet for details regarding the exposed thermal pad features and dimensions, if present.

THERMAL PAD MECHANICAL DATA

DPD (S-PUSON-N12)

PLASTIC SMALL OUTLINE NO-LEAD

THERMAL INFORMATION

This package incorporates an exposed thermal pad that is designed to be attached directly to an external heatsink. The thermal pad must be soldered directly to the printed circuit board (PCB). After soldering, the PCB can be used as a heatsink. In addition, through the use of thermal vias, the thermal pad can be attached directly to the appropriate copper plane shown in the electrical schematic for the device, or alternatively, can be attached to a special heatsink structure designed into the PCB. This design optimizes the heat transfer from the integrated circuit (IC).

For information on the Quad Flatpack No-Lead (QFN) package and its advantages, refer to Application Report, QFN/SON PCB Attachment, Texas Instruments Literature No. SLUA271. This document is available at www.ti.com.

The exposed thermal pad dimensions for this package are shown in the following illustration.

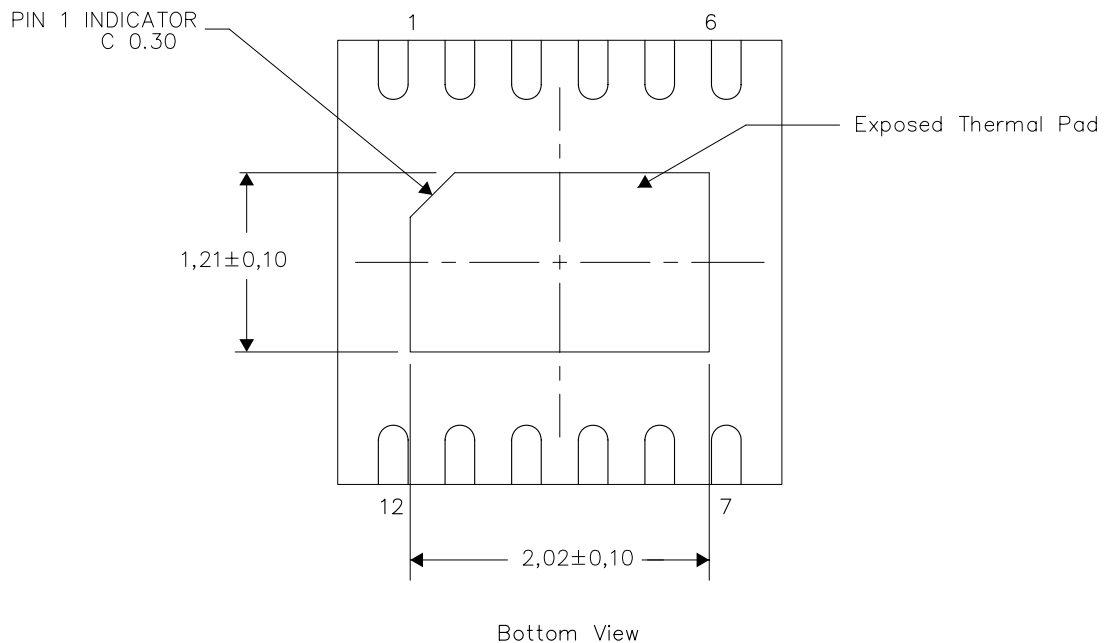

Exposed Thermal Pad Dimensions

4212468/A 02/12

NOTE: All linear dimensions are in millimeters

IMPORTANT NOTICE

Texas Instruments Incorporated and its subsidiaries (TI) reserve the right to make corrections, enhancements, improvements and other changes to its semiconductor products and services per JESD46, latest issue, and to discontinue any product or service per JESD48, latest issue. Buyers should obtain the latest relevant information before placing orders and should verify that such information is current and complete. All semiconductor products (also referred to herein as "components") are sold subject to TI's terms and conditions of sale supplied at the time of order acknowledgment.

TI warrants performance of its components to the specifications applicable at the time of sale, in accordance with the warranty in TI's terms and conditions of sale of semiconductor products. Testing and other quality control techniques are used to the extent TI deems necessary to support this warranty. Except where mandated by applicable law, testing of all parameters of each component is not necessarily performed.

TI assumes no liability for applications assistance or the design of Buyers' products. Buyers are responsible for their products and applications using TI components. To minimize the risks associated with Buyers' products and applications, Buyers should provide adequate design and operating safeguards.

TI does not warrant or represent that any license, either express or implied, is granted under any patent right, copyright, mask work right, or other intellectual property right relating to any combination, machine, or process in which TI components or services are used. Information published by TI regarding third-party products or services does not constitute a license to use such products or services or a warranty or endorsement thereof. Use of such information may require a license from a third party under the patents or other intellectual property of the third party, or a license from TI under the patents or other intellectual property of TI.

Reproduction of significant portions of TI information in TI data books or data sheets is permissible only if reproduction is without alteration and is accompanied by all associated warranties, conditions, limitations, and notices. TI is not responsible or liable for such altered documentation. Information of third parties may be subject to additional restrictions.

Resale of TI components or services with statements different from or beyond the parameters stated by TI for that component or service voids all express and any implied warranties for the associated TI component or service and is an unfair and deceptive business practice. TI is not responsible or liable for any such statements.

Buyer acknowledges and agrees that it is solely responsible for compliance with all legal, regulatory and safety-related requirements concerning its products, and any use of TI components in its applications, notwithstanding any applications-related information or support that may be provided by TI. Buyer represents and agrees that it has all the necessary expertise to create and implement safeguards which anticipate dangerous consequences of failures, monitor failures and their consequences, lessen the likelihood of failures that might cause harm and take appropriate remedial actions. Buyer will fully indemnify TI and its representatives against any damages arising out of the use of any TI components in safety-critical applications.

In some cases, TI components may be promoted specifically to facilitate safety-related applications. With such components, TI's goal is to help enable customers to design and create their own end-product solutions that meet applicable functional safety standards and requirements. Nonetheless, such components are subject to these terms.

No TI components are authorized for use in FDA Class III (or similar life-critical medical equipment) unless authorized officers of the parties have executed a special agreement specifically governing such use.

Only those TI components which TI has specifically designated as military grade or "enhanced plastic" are designed and intended for use in military/aerospace applications or environments. Buyer acknowledges and agrees that any military or aerospace use of TI components which have **not** been so designated is solely at the Buyer's risk, and that Buyer is solely responsible for compliance with all legal and regulatory requirements in connection with such use.

TI has specifically designated certain components as meeting ISO/TS16949 requirements, mainly for automotive use. In any case of use of non-designated products, TI will not be responsible for any failure to meet ISO/TS16949.

Products

Audio	www.ti.com/audio
Amplifiers	amplifier.ti.com
Data Converters	dataconverter.ti.com
DLP® Products	www.dlp.com
DSP	dsp.ti.com
Clocks and Timers	www.ti.com/clocks
Interface	interface.ti.com
Logic	logic.ti.com
Power Mgmt	power.ti.com
Microcontrollers	microcontroller.ti.com
RFID	www.ti-rfid.com
OMAP Applications Processors	www.ti.com/omap
Wireless Connectivity	www.ti.com/wirelessconnectivity

Applications

Automotive and Transportation	www.ti.com/automotive
Communications and Telecom	www.ti.com/communications
Computers and Peripherals	www.ti.com/computers
Consumer Electronics	www.ti.com/consumer-apps
Energy and Lighting	www.ti.com/energy
Industrial	www.ti.com/industrial
Medical	www.ti.com/medical
Security	www.ti.com/security
Space, Avionics and Defense	www.ti.com/space-avionics-defense
Video and Imaging	www.ti.com/video

TI E2E Community

e2e.ti.com